

# alphaJET C-HS Inkjet printer

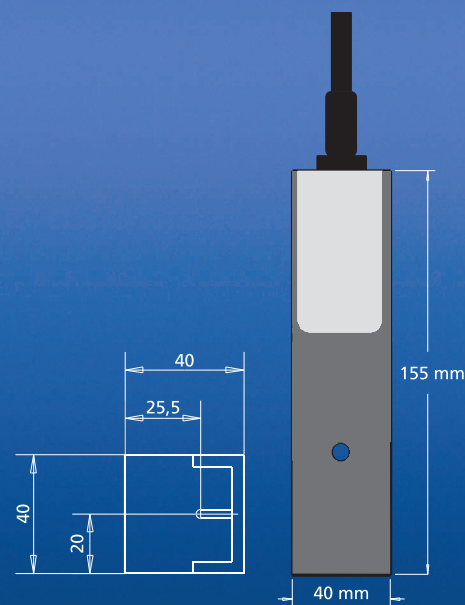

Measurements of High-Speed print head:



The easy-to-operate InkJET system for fast and economical marking produces excellent print quality at low text heights.

alphaJET C-HS (HS = High-Speed) was developed to meet increasing speed requirements in conjunction with very small type size but excellent typography – particularly for single-line cable coding, – and also in order to defend our role as leader for special niche applications in marking technology. The print head had to be adapted in order to reach these speeds with a 55 µ nozzle. These changes are visible: the printhead housing dimensions were reduced and the upper and lower deflection units shortened. Geared to the requirements of the cable industry, four inks are currently being used in the alphaJET C-HS.

## Technical Data

Dimensions:	Control unit: 295 x 320 x 655 mm (incl. operation terminal), L x W x H Print head: 40 x 40 x 155 mm, L x W x H
Weight:	approx. 27 kg
Housing:	stainless steel IP 54
Printing system:	continuous inkJET system consisting of control unit and printing unit
Ink system:	0.5 l storage bottle. Easy to refill. No air pressure necessary.
Ink types:	Wide range of inks available, depending on product material and application
Working conditions:	temperature + 10° up to + 35° C, relative humidity max. 90 %, non-condensing
Operation:	easy operation via an integrated or external terminal. Graphical user-interface (WYSIWYG).
Hardware features:	Interface for integration into network of several machines. control unit and printing unit are independent of one another. Hence, further printing units can be controlled and synchronised by one single master unit. Peripheral equipment, e.g. xy axes systems, image recognition control, separating devices or code reader are controlled and synchronised via a previously defined interface.
Texts:	automatic date, expiry date, Julian date, current numbering, time, shift identification, barcodes, logos etc.
Error diagnosis:	automatic error diagnosis in full text display
Print speed:	up to 2500 characters per second
Distance print head-item:	1 - 8 mm
Print height:	0.032" - 0.12" (0.8 - 3 mm) (1 line)
Print resolution:	7 dots in vertical direction. Free choice of print matrix. Any matrix combination possible within one text.
Interface:	2 x RS 232
Supply voltage:	115 / 230 V AC ± 10 %, 50 / 60 Hz, power consumption max. 1.0 / 0.5 A
Safety standard:	ink return control. Viscosity and ink level control. Remote monitoring of printing errors. Separate installation of electronics and ink system. Almost emission-free. Protection against ingress of liquids (housing) : IP 54

Subject to technical modification